

AIR PREPARATION UNITS FILTER WITH METAL BOWL Series F1M

Cat No F1M - 02 - C

FILTER WITH METAL BOWL - 1/8, 1/4, 3/8, 1/2, 3/4, 1"

Features

- For higher pressure range above 10 bar
- Suitable for Modular mounting
- Aluminium bowl guard, bayonet type (3/4 and 1" only)
- Press type Manual drain for easy operation
- Suitable for Internal autodrain also
- Bronze filtering element
- Separator and shield for efficient moisture separation



Application

These type of filters are used for Chemical, Paintshops, Pharmaceutical, Foundry etc.

Technical Specifications

Model	F13...M	F14...M	F15...M	F17...M	F17...M
Medium	Compressed air				
Port size	NPT 1/8 (G1/8) NPT 1/4 (G1/4)	NPT 1/4 (G1/4) NPT 3/8 (G3/8)	NPT 1/4 (G1/4) NPT 3/8 (G3/8) NPT 1/2 (G1/2)	NPT 3/4 (G3/4)	NPT 1 (G1)
Flow rate in scfm (NI / min) @	14.88 (425) 28 (800)	26.78 (765) 78.75 (2250)	28.53 (815) 76.48 (2185) 122.5 (3500)	175 (5000)	227.5 (6500)
Max supply pressure in psi (bar)	280 (20)				
Ambient / Medium temperature	41° - 140° F (5° - 60° C)				
Filtration in microns #	1, 5, 25, 40 (standard), 50, 100				
Bowl capacity in ounce (ml) (at maximum condensate level)	0.30 (9)	2.16 (64)	3.1 (90)	5.58 (165)	5.58 (165)
Bowl material	Aluminium				
Installation	Vertical (as in the picture)				
Materials of construction	Aluminium, Bronze, Steel, Acetal, SS, Nitrile				
Optional accessories *	Clamp, Modular mounting kit				
Weight in lb (Kg)	0.44 (0.20)	0.99 (0.45)	1.87 (0.85)	3.24 (1.47)	3.15 (1.43)

@ Supply pressure 85 psi (6 bar) , pressure drop $\Delta p = 4$ psi (0.3 bar) (For standard models).

For details see " How to order ".

* For details refer Optional accessories Cat No APA - 02 - C

Precautions

1. Note the direction of flow before installation and connect piping accordingly.
2. Flush pipings for dirt, dust, rust and other foreign particles.
3. Install in clean atmosphere.
4. Nipples of taper threads (R) to be used with teflon tape. Ensure teflon tape does not enter the unit during tightening.
Nipples of straight threads (G) to be used with sealing washer.

AIR PREPARATION UNITS FILTER WITH METAL BOWL Series F1M

Cat No F1M - 02 - C

Model F13...M

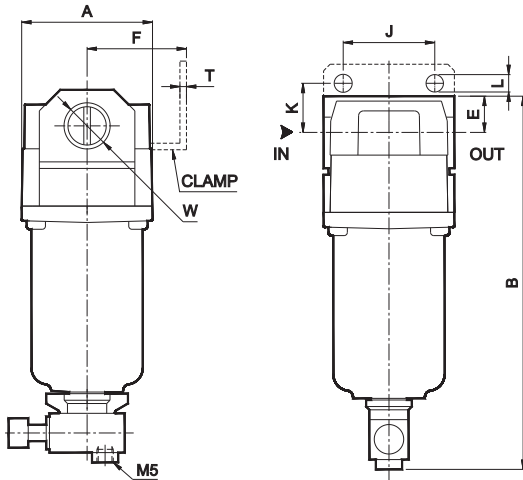

Model F14...M & F15...M

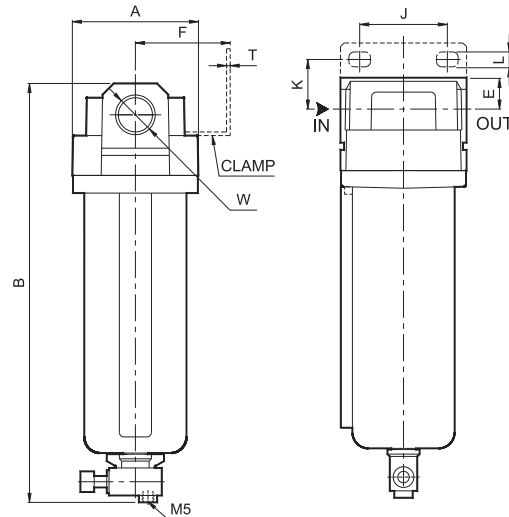

Model F17....-MM

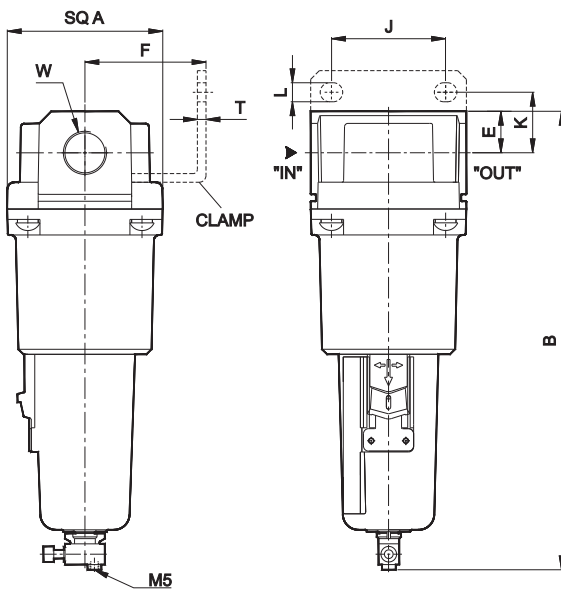

Model F17....-LM

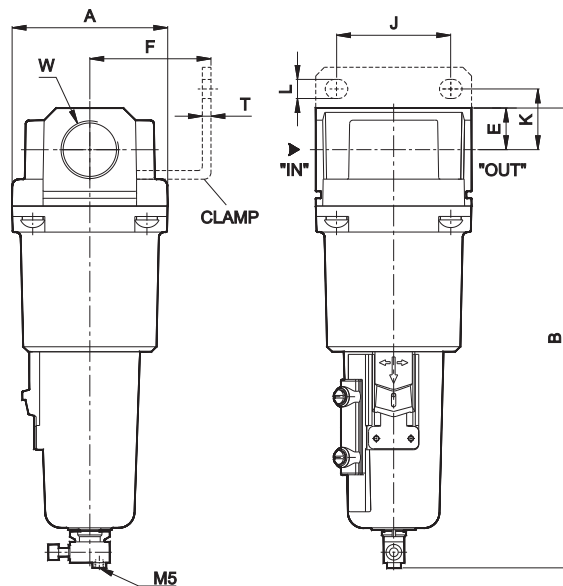

Model	W		A	B	E	K	F	J	L	T
F13...M	NPT 1/8 (G1/8) NPT 1/4 (G1/4)	Inch (mm)	SQ 1.575 (40)	4.528 (115)	0.43 (11)	0.59 (15)	1.181 (30)	1.102 (28)	0.216 (5.5)	0.079 (2)
F14...M	NPT 1/4 (G1/4) NPT 3/8 (G3/8)	Inch (mm)	SQ 2.165 (55)	7.402 (188)	0.55 (14)	0.98 (25)	1.575 (40)	1.575 (40)	0.256 (6.5)	0.079 (2)
F15...M	NPT 1/4 (G1/4) NPT 3/8 (G3/8) NPT 1/2 (G1/2)	Inch (mm)	SQ 2.756 (70)	8.819 (224)	0.71 (18)	0.98 (25)	1.968 (50)	2.165 (55)	0.335 (8.5)	0.079 (2)
F17...M	NPT 3/4 (G3/4)	Inch (mm)	SQ 3.543 (90)	10.433 (265)	0.95 (24)	1.38 (35)	2.756 (70)	2.598 (66)	0.433 (11)	0.196 (5)
F17...M	NPT 1 (G1)	Inch (mm)	SQ 3.543 (90)	10.433 (265)	0.95 (24)	1.38 (35)	2.756 (70)	2.598 (66)	0.433 (11)	0.196 (5)

For Details of Clamp see optional accessories Cat No APA - 02 - C

AIR PREPARATION UNITS

FILTER WITH METAL BOWL Series F1M

Cat No F1M - 02 - C

Flow Graphs

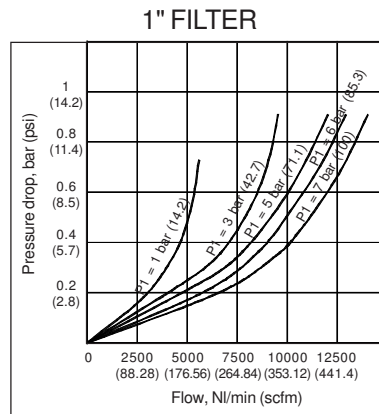
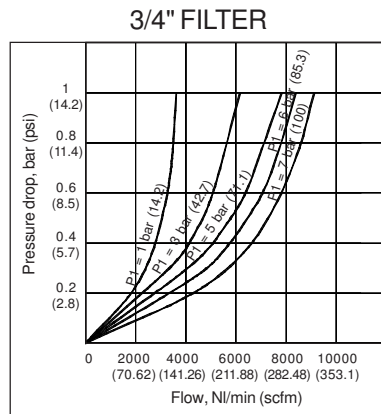
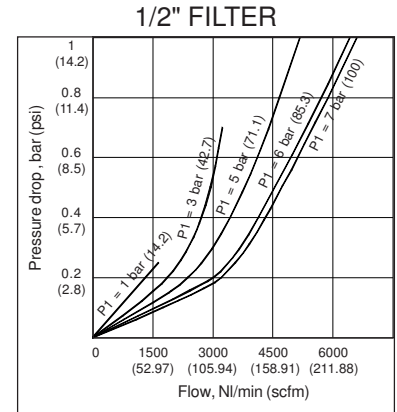
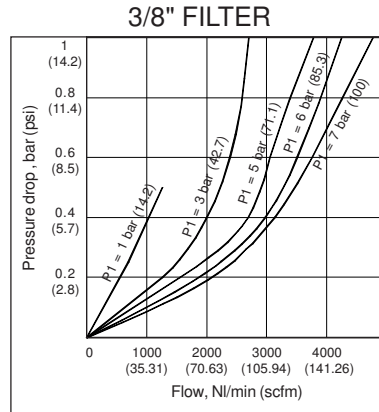
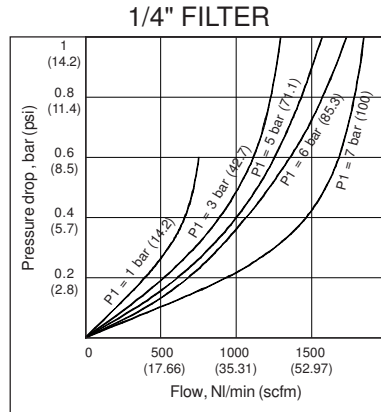

Flow graphs are for 40µm filtrations only

How to order

F1

Body & Port size	
390 (360)	NPT1/8 (G1/8)
391 (361)	NPT1/4 (G1/4)
491 (461)	NPT1/4 (G1/4)
492 (462)	NPT3/8 (G3/8)
591 (561)	NPT1/4 (G1/4)
592 (562)	NPT3/8 (G3/8)
593 (563)	NPT1/2 (G1/2)
794 (764)	NPT3/4 (G3/4)
795 (765)	NPT1 (G1)

Filtration in microns	
0	- 1
1	- 5
2	- 25
3	- 40 (Standard)
4	- 50
5	- 100

Metal bowl	
M	Without level indicator
L*	With level indicator

Drain arrangement	
M	Manual drain (Standard)
A*	Auto drain

** Applicable for F14, F15 & F17 series only.

Ordering example :- Filter - 3/8 size (with NPT 3/8 (G3/8) port) with 50 microns and Metal bowl with Auto drain
Ordering No: F1492 (1462) 4 - MA.

If ordered as 3/8 Filter with Metal bowl, our standard model F1492 (1462) 3 - MM, with 40 microns will be supplied.

- For safety instructions, please refer instruction manual IS - F1M - 2 - 01

Subject to change